



ACCESSORY PRODUCTS

LOW-RISE FOAM ADHESIVES

TECHNICAL BULLETIN

191219SCANE



(Supersedes -)



ROOFS WALLS FOUNDATIONS PARKING DECKS BRIDGES ADDITIONAL EXPERTISE



WATERPROOFING



INSULATION



VEGETATIVE SOLUTIONS



SOUNDPROOFING



COMPLEMENTARY PRODUCTS

INTRODUCTION

Roof assemblies which components are installed with cold adhesives have grown in popularity over the last decade. This prominence is due to the quality of the products developed, which are offered as an alternative to traditional material adherence methods. In particular, low-rise polyurethane foam adhesives have properties and performance criteria that are superior to conventional bonding methods used in roofing.

In this product line, SOPREMA offers two-component polyurethane-based adhesives: DUOTACK and DUOTACK 365.

Although it is becoming less popular, oxidized bitumen (Type II and III asphalt) is still used to adhere various components of roofing systems. However, asphalt has no flexibility at temperatures below 0 °C and is significantly softened in hot summer temperatures. In contrast, DUOTACK adhesives maintain their properties over a wide range of temperatures, eliminating liquefaction problems in hot weather or crystallization in cold weather.

These adhesives also provide good resistance to negative wind loads while eliminating thermal bridging from screws and plates.

The creation of the CSA A123.21 Standard has demonstrated excellent resistance of adhesive bonded membrane roofing systems, classified as adhesive-applied roofing systems (AARS).

To ensure the long-term performance of roof assemblies adhered with DUOTACK, it is important to understand the subtleties of the product, which means understanding its limits, the tools required and the importance of respecting the correct methods of use and the quantities prescribed. A good knowledge of the product will benefit the installers, but also the inspectors mandated to supervise the work. It is also important to have a good understanding of product approvals in order to specify the products properly.

Before installing the DUOTACK adhesive, installers should be familiar with the terminology related to low-rise polyurethane foam adhesives. They must also know the limitations of the product, especially regarding the installation temperatures, and the product conditioning before installation.

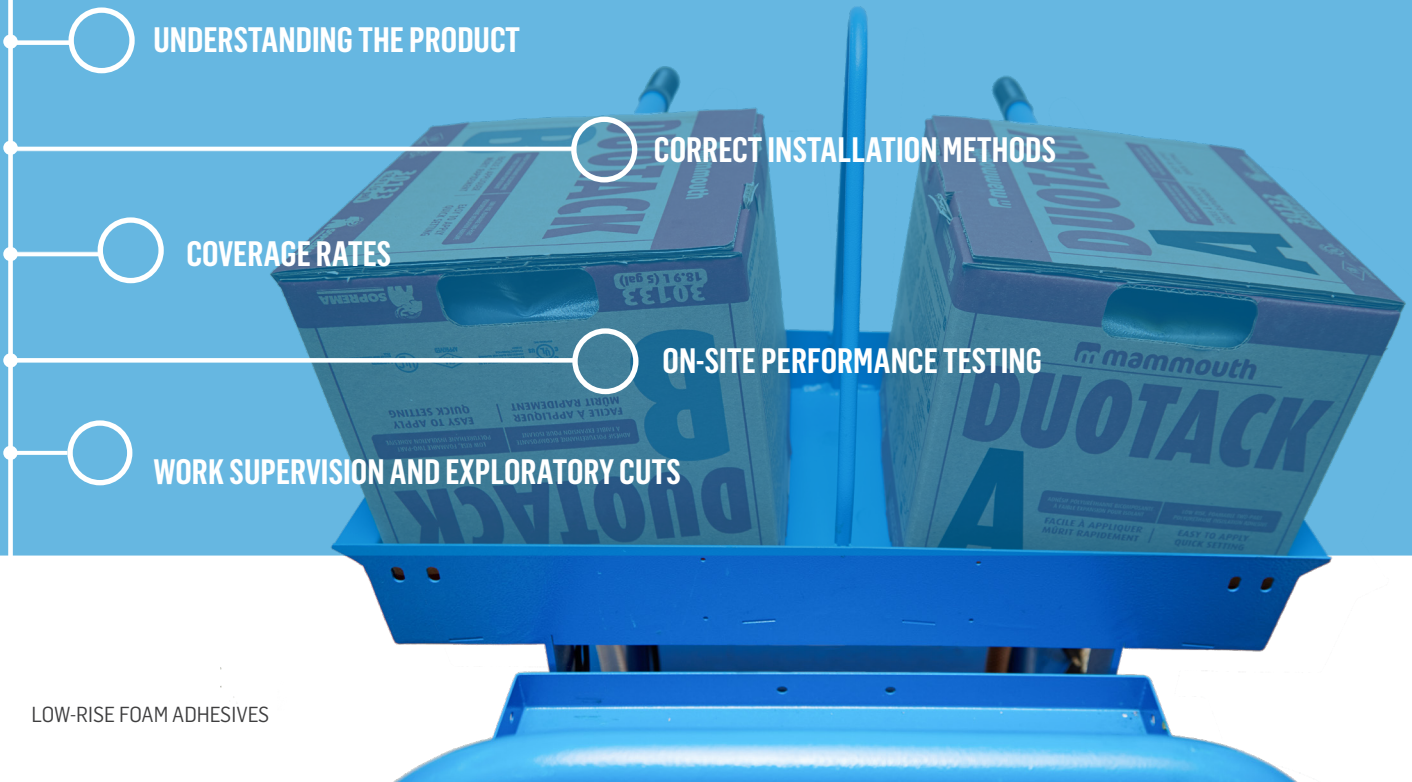

1 – UNDERSTANDING THE PRODUCT

DUOTACK and DUOTACK 365 are polyurethane resin-based adhesives consisting of a reactive hardener part (Part A) and a part composed of polyols and other additives to promote adhesion (Part B).

Mixing the two parts makes the resin rise, then harden. During this process, the product goes through a “Cream phase”, a “Rising phase” and finally a “Setting phase” which leads to complete curing.

The length of these different phases varies according to ambient temperature and the humidity. These phases generally occur faster in hot and humid weather and take longer in cold, dry weather. Ultimately, when properly mixed, they will occur regardless of the ambient temperature because of the chemical reaction that occurs when Part A is properly mixed with Part B. This is true for both DUOTACK and DUOTACK 365.

The difference between DUOTACK and DUOTACK 365 is the viscosity of Parts A and B at low temperature. DUOTACK 365 was designed with a lower viscosity in cold weather to facilitate the use of cubitainers in winter without the requirement to condition the product when using at temperatures down to -10 °C. Conditioning is the process of keeping the adhesive at a sufficiently warm temperature in order to maintain the viscosity of Parts A and B at a level allowing a homogeneous mixture. The use of regular DUOTACK without conditioning in cold weather can cause an imbalance in the ratios of Parts A and B and thus compromise the quality of the foam and its reaction time.

Terminology related to DUOTACK

Conditioning: Storage of the product at a specific minimum temperature according to a specified time prior to use at cold temperatures

Cream time: Short period when Parts A and B start to react

Rising time: Rise of the adhesive bead

Setting time: Hardening period when the adhesive no longer rises

Curing time: Final state of the adhesive

2 – CORRECT INSTALLATION METHODS

EXTRUSION

DUOTACK is applied using tools to extract the product from its packaging.

1.5 L cartridges are applied using a battery applicator. (Figure 1)

Cubitainers are applied with the DUOTACK applicator extrusion tool. Installers should refer to the “DUOTACK Installer’s Guide” available on SOPREMA’s website to keep the equipment in proper operating condition, to learn more about the installation and the storage of the DUOTACK applicator. (Figure 2)



Figure 1



Figure 2

APPLICATION RULES

Rule 1 – DUOTACK should be applied in continuous strips of 13 to 19 mm ($\frac{1}{2}$ to $\frac{3}{4}$ inches) wide at the moment of the application.

DUOTACK's expansion and curing occurs when Parts A and B mix in the static mixer. The expansion speed of the adhesive depends on several factors, including temperature and humidity as well as wind and direct exposure to sun. For example, in hot, humid weather, expansion will be quicker, while in winter, it will be slower. As a result, the installer must consider these factors when gauging the application speed of the adhesive beads and when to set the subsequent layers into the adhesive.

A rapid expansion of the adhesive in the summer can give the installer the false impression of applying a 13 to 19 mm ($\frac{1}{2}$ to $\frac{3}{4}$ in) bead through the output of the static mixer. An adhesive bead, once expanded and covered with a panel, should vary in width from 38 mm to 64 mm (1.5 to 2.5 in) regardless of temperature. The width shall be increased once pressure is applied on the installed panel. If this width is not reached the application speed is too fast and the amount of adhesive applied is insufficient.

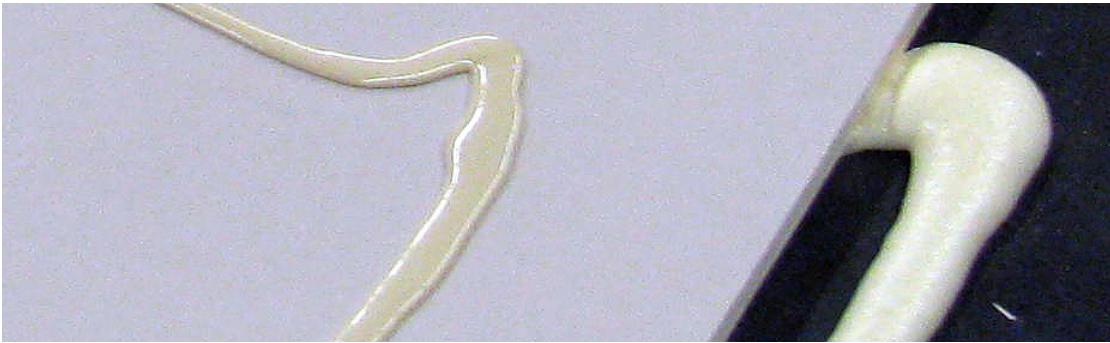

Rule 2 – During application, it is important to immediately place the boards over the applied adhesive.

The setting of the adhesive starts as soon as the rising time is completed. During the rising time, the surface of the adhesive begins to gradually dry from the outside to the inside. The panel installation must be done before the surface of the bead is dry to the touch. Waiting too long may reduce the adhesion surface on the laid panel.

Rule 3 – Apply weight on the panels.

Once the panel is laid on the adhesive beads, weight shall be applied to maximize adhesion of the panels. This weight must be applied in a reasonable time at the beginning when the adhesive sets. Putting on weight in the middle of the setting phase may weaken the bond. Weight will have no effect if the setting period is over.

Rule 4 – Adhesive must always be stored at the temperatures indicated on the technical data sheet until the application. This is called product conditioning.

Proper conditioning allows one to obtain the ideal chemical reaction between the two parts by allowing the simultaneous extrusion of these two parts in equal volume. See the technical data sheets to review the conditioning recommendations.

3 – COVERAGE

The coverage of the adhesive indicated on the data sheets is determined by calculating regular continuous beads spaced 300 mm (12 in) apart and installed according to the prescribed method.

Depending on the size of the panels adhered and for practical reasons, the beads are often applied in an "S" pattern. The cubic containers used with the DUOTACK applicator allow for larger continuous beads, while the 1.5 L cartridges used with battery extruders will result in more frequent "S" pattern recurrence. The more continuous the beads, the higher the total covering power.

Suggested layout depending on the dimensions of the panels:

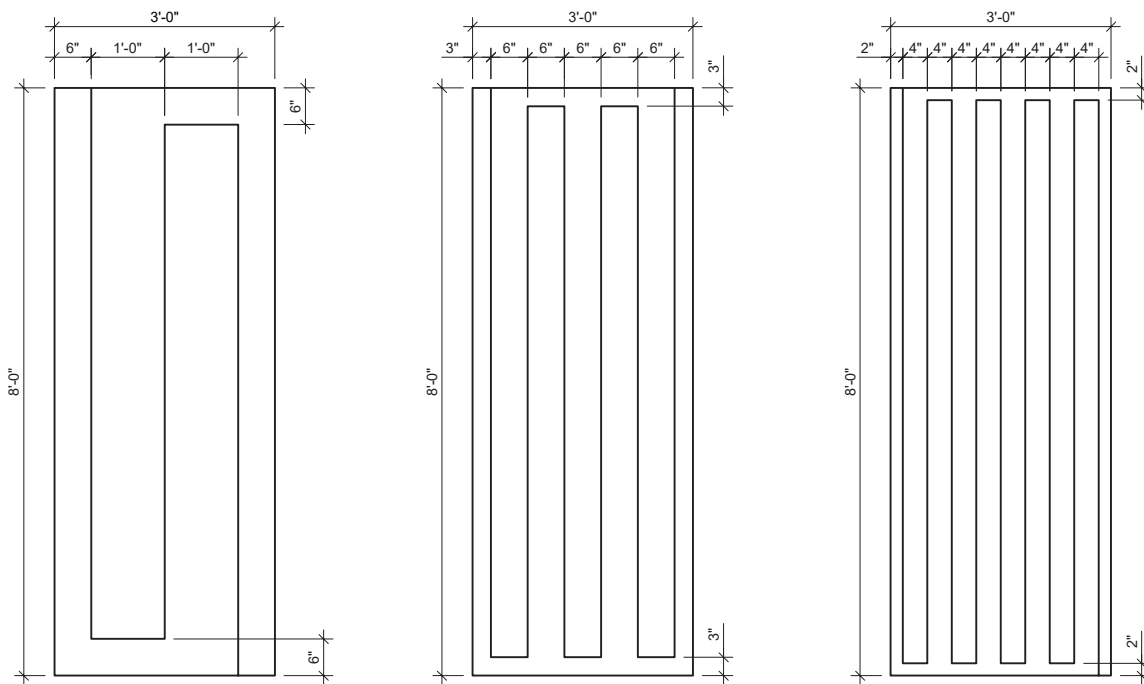

3' x 8' SOPRASMART

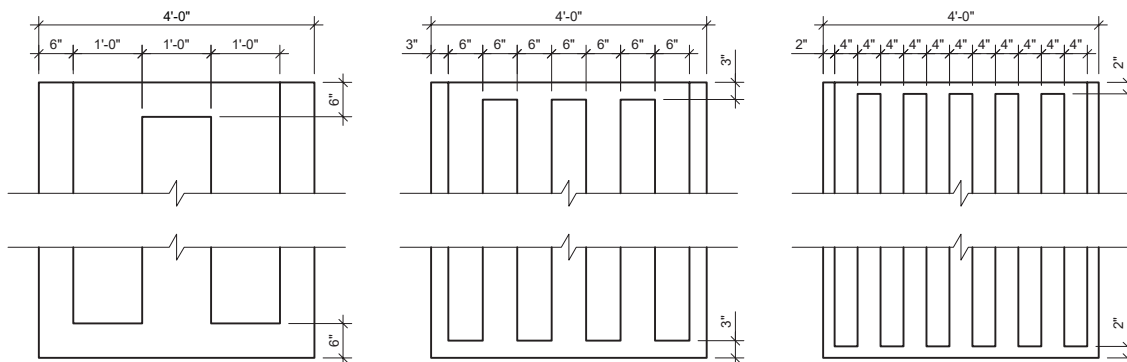

4' x 4' — 4' x 5' — 4' x 8' BOARDS

Note: SOPREMA does not recommended to glue 4 x 8 ft polyisocyanurate panels with DUOTACK or DUOTACK 365 adhesives.

4 – ON-SITE PERFORMANCE TESTING

There are various field testing methods used to assess the adherence of adhered roof systems, namely ANSI/SPRI Standard Field Test Procedure for Determining the Mechanical Uplift Resistance of Insulation Adhesives over Various Substrates and FM PLPDS 1-52 Field Uplift Testing. These so-called "small scale" methods compare the strength of the assembly between the different areas of the roof or the average force obtained on the site using a sampling of several models created in a laboratory using the same method. In order to obtain a valid comparison, all of these on-site and laboratory tests must be performed with the same materials from the same manufacturers and under similar installation conditions. These methods may also be useful for predicting the condition of a roof after exposure to strong winds (hurricane, tornado or severe thunderstorm) to determine which areas should be repaired.

Using one of the methods mentioned above on a roof could possibly lead to significant legal entanglements. Cutting into a completed roof assembly may affect warranties while the interpretation of results may challenge the accountability of work inspection firms and contractors. Consequently, these interventions should always be entrusted to a specialized firm independent of the project carried out with certified and competent employees. All parties involved in the roofing work; owner, installer, consultant and manufacturer should always be involved in discussions around site validation work.

These small-scale tests do not provide results as accurate as large-scale tests completed in a controlled environment. Depending on the quantity and quality of the tests carried out, the interpretation of the results obtained can be subjective.

In no case should the results of these small-scale tests be compared with CSA 123.21 Standard test method for the dynamic wind uplift resistance, or even the FM 4470 static method. Results obtained by larger-scale tests involve more complex dynamics between materials. Firstly, the test format gives an average result for products adhered by several rows of adhesives. They also include cycles at different pressures as well as the notion of fatigue on materials over a specified time period (up to +/- 8 hours). Small-scale tests are limited to constant pressure applied over a short time period and to a sample potentially held by only one or two beads of adhesive. Moreover, they are carried out in an uncontrolled environment where the temperature, the exposure to sun and the relative humidity can influence the result obtained. So these results won't be comparable to that of a dynamic wind uplift test completed in the laboratory.



5 – WORK SUPERVISION AND EXPLORATORY CUTS

Supervisors of works should take into account the recommendations presented in this bulletin, particularly regarding the bead size to rising time ratio and the product conditioning.

Most roof assemblies are tested with adhesive beads installed every 300 mm (12 in) or 150 mm (6 in). The distance between the beads may vary slightly depending on the installer's methods, but the average should be as specified. Note that the application average should only take into account the linear pattern of the adhesive beads. The perpendicular beads that connect each longitudinal bead ("S" pattern) are not required and do not count in the wind uplift resistance results obtained in the laboratory. Perpendicular beads should therefore not be subject to special assessment during roofing work supervision.

It is far better to confirm the quality of the adhesive installation during the project than after its completion. The adequate supervision of adhesive application—made as per the professional specifications and the manufacturer's recommendations—is the best guarantee of success regarding adhered systems.

Exploratory cuts should only be performed if there is an obvious sign of defects in the roofing system or if there is reasonable doubt about the installation quality on projects that have not been supervised. Making exploratory cuts on a new roof can cause performance problems and invalidate the warranty on materials or labour. In all cases, it is important to notify the contractor in writing, as well as all manufacturers who have supplied materials used in the roofing system. The repair works required following exploratory cuts must be carried out in accordance with the recommendations of the issuers of guarantees.

Exploratory cuts should be large enough to show the average adhesive applied on more than one bonded panel. Depending on the defects observed, more than one cut may be required on each area of the roof.

If you have questions about this technical bulletin, please contact your SOPREMA representative.