

CUT A-A
Side laps

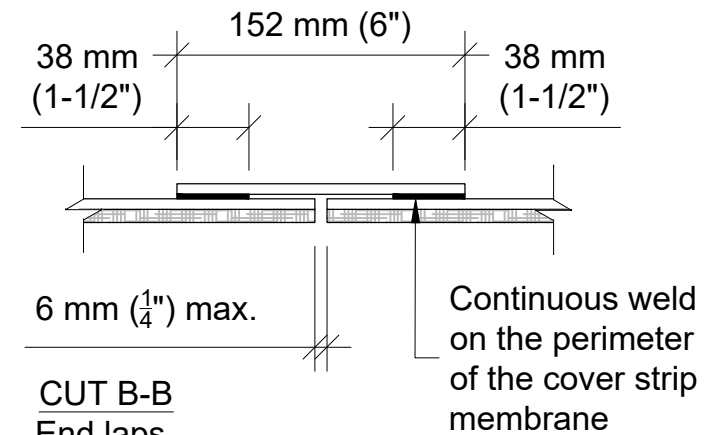

CUT B-B
End laps

COPYRIGHT 2021 SOPREMA

Title:
FLEECE-BACK SENTINEL PVC MEMBRANE LAPS

Scale:
Varies

Date:
JAN. 2021

Drawing number:
SOP146-02

